

COMPLEMENTARY SILICON POWER TRANSISTORS

- TIP31A, TIP31C, TIP32A AND TIP32C ARE SGS-THOMSON PREFERRED SALESTYPES

DESCRIPTION

The TIP31A, TIP31B and TIP31C are silicon epitaxial-base NPN power transistors in Jedec TO-220 plastic package, intended for use in medium power linear and switching applications. The complementary PNP types are TIP32A, TIP32B and TIP32C.

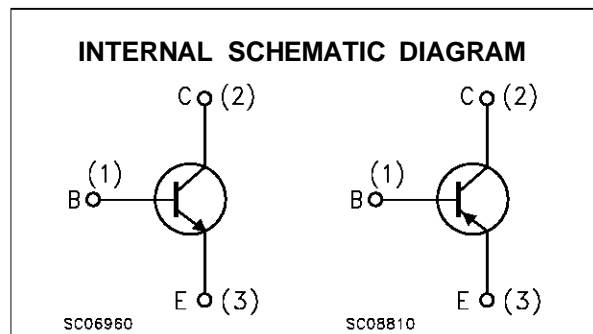
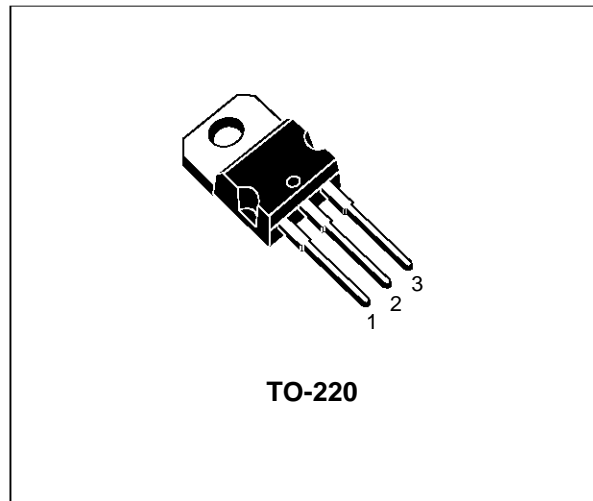

ABSOLUTE MAXIMUM RATINGS

Symbol	Parameter	Value			Unit	
		NPN	TIP29A	TIP29B		TIP29C
		PNP	TIP30A	TIP30B		TIP30C
V_{CBO}	Collector-Base Voltage ($I_E = 0$)	60	80	100	V	
V_{CEO}	Collector-Emitter Voltage ($I_B = 0$)	60	80	100	V	
V_{EBO}	Emitter-Base Voltage ($I_C = 0$)	5			V	
I_C	Collector Current	1			A	
I_{CM}	Collector Peak Current	3			A	
I_B	Base Current	0.4			A	
P_{tot}	Total Dissipation at $T_{case} \leq 25\text{ }^\circ\text{C}$ $T_{amb} \leq 25\text{ }^\circ\text{C}$	30			W	
		2			W	
T_{stg}	Storage Temperature	-65 to 150			$^\circ\text{C}$	
T_j	Max. Operating Junction Temperature	150			$^\circ\text{C}$	

For PNP types voltage and current values are negative.

TIP29A/TIP29B/TIP29C/TIP30A/TIP30B/TIP30C

THERMAL DATA

R _{thj-case}	Thermal Resistance Junction-case	Max	4.17	°C/W
R _{thj-amb}	Thermal Resistance Junction-ambient	Max	62.5	°C/W

ELECTRICAL CHARACTERISTICS (T_{case} = 25 °C unless otherwise specified)

Symbol	Parameter	Test Conditions	Min.	Typ.	Max.	Unit
I _{CBO}	Collector Cut-off Current (I _B = 0)	for TIP29A/30A V _{CE} = 30 V for TIP29B/29C/30B/30C V _{CB} = 60 V			0.3	mA
I _{CES}	Collector Cut-off Current (V _{BE} = 0)	for TIP29A/30A V _{CE} = 60 V for TIP29B/30B V _{CE} = 80 V for TIP29C/30C V _{CE} = 100 V			0.2	mA
I _{EBO}	Emitter Cut-off Current (I _C = 0)	V _{EB} = 5 V			1	mA
V _{CEO(sus)} *	Collector-Emitter Sustaining Voltage (I _B = 0)	I _C = 30 mA for TIP29A/30A for TIP29B/30B for TIP29C/30C	60 80 100			V V V
V _{CE(sat)} *	Collector-Emitter Saturation Voltage	I _C = 1 A I _B = 125 mA			0.7	V
V _{BE(on)} *	Base-Emitter Voltage	I _C = 1 A V _{CE} = 4 V			1.3	V
h _{FE} *	DC Current Gain	I _C = 0.2 A V _{CE} = 4 V I _C = 1 A V _{CE} = 4 V	40 15		75	
h _{fe}	Small Signal Current Gain	I _C = 0.2 A V _{CE} = 10 V f = 1 KHz I _C = 0.2 A V _{CE} = 10 V f = 1 MHz	20 3			

* Pulsed: Pulse duration = 300 μs, duty cycle ≤ 2 %
For PNP types voltage and current values are negative.

TO-220 MECHANICAL DATA

DIM.	mm			inch		
	MIN.	TYP.	MAX.	MIN.	TYP.	MAX.
A	4.40		4.60	0.173		0.181
C	1.23		1.32	0.048		0.051
D	2.40		2.72	0.094		0.107
D1		1.27			0.050	
E	0.49		0.70	0.019		0.027
F	0.61		0.88	0.024		0.034
F1	1.14		1.70	0.044		0.067
F2	1.14		1.70	0.044		0.067
G	4.95		5.15	0.194		0.203
G1	2.4		2.7	0.094		0.106
H2	10.0		10.40	0.393		0.409
L2		16.4			0.645	
L4	13.0		14.0	0.511		0.551
L5	2.65		2.95	0.104		0.116
L6	15.25		15.75	0.600		0.620
L7	6.2		6.6	0.244		0.260
L9	3.5		3.93	0.137		0.154
DIA.	3.75		3.85	0.147		0.151

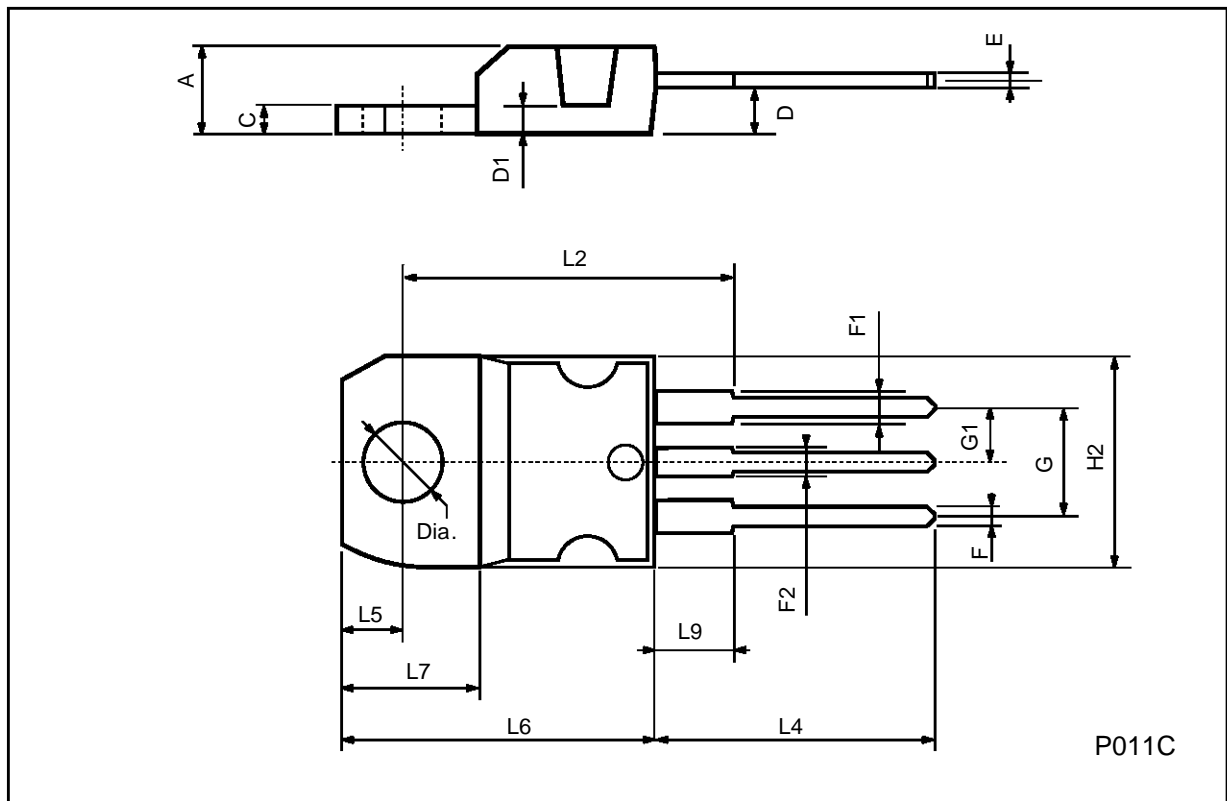

Information furnished is believed to be accurate and reliable. However, SGS-THOMSON Microelectronics assumes no responsibility for the consequences of use of such information nor for any infringement of patents or other rights of third parties which may result from its use. No license is granted by implication or otherwise under any patent or patent rights of SGS-THOMSON Microelectronics. Specifications mentioned in this publication are subject to change without notice. This publication supersedes and replaces all information previously supplied. SGS-THOMSON Microelectronics products are not authorized for use as critical components in life support devices or systems without express written approval of SGS-THOMSON Microelectronics.

© 1995 SGS-THOMSON Microelectronics - Printed in Italy - All Rights Reserved

SGS-THOMSON Microelectronics GROUP OF COMPANIES

Australia - Brazil - Canada - China - France - Germany - Hong Kong - Italy - Japan - Korea - Malaysia - Malta - Morocco - The Netherlands - Singapore - Spain - Sweden - Switzerland - Taiwan - Thailand - United Kingdom - U.S.A